

Cisco Meraki MS400 Series Cloud Managed Aggregation Switches



OVERVIEW

The Cisco Meraki MS400 Series is the world's first range of cloud-managed 1 Gigabit and 10 Gigabit aggregation switches, bringing the benefits of the cloud: simplified management, reduced complexity, network wide visibility and control, and lower cost for campus deployments.

EXPANDING CLOUD MANAGEMENT TO THE CAMPUS

Cisco Meraki aggregation switches extend Meraki's cloud management to campus deployments. Just like our access switches, these aggregation switches are built from the ground up to be easy to manage without compromising any of the power and flexibility traditionally found in enterprise-class switches.

Meraki switches are managed through an elegant, intuitive cloud interface, rather than a cryptic command line. To bring up a Meraki switch, just plug it in; there's no need for complicated configuration files — or pre-staging.

INDUSTRY-LEADING CLOUD MANAGEMENT

Cloud management has a number of benefits that make it easier to build campus networks:

- Centralized management that allows you to manage your entire Meraki network stack from campus aggregation to your access layer (wireless APs, switches, firewalls).
- Stack for high density fiber aggregation and manage up to tens of thousands of ports from a single pane of glass.
- Layer 7 OS, client, and hostname fingerprinting.
- E-mail and SMS (text) alerts upon power loss, downtime, or configuration changes.
- Role-based administration and automatic, scheduled firmware upgrades over the web.
- Regular feature updates and enhancements delivered on demand from the Meraki cloud.
- True zero-touch provisioning

Meraki switches feature high-end hardware features, including:

- Compact, 1RU design for space-constrained environments
- Up to 960 Gbps of non-blocking switching capacity (MS420)
- Field-replaceable, hot-swappable power supplies
- Field-replaceable, hot-swappable fans
- Front-to-back cooling
- Dedicated management port
- Low power consumption and shallow rack depth, which enable flexible deployment
- Stacking option for building redundant architectures

Designed for a Complete Cloud-Managed Switch Network

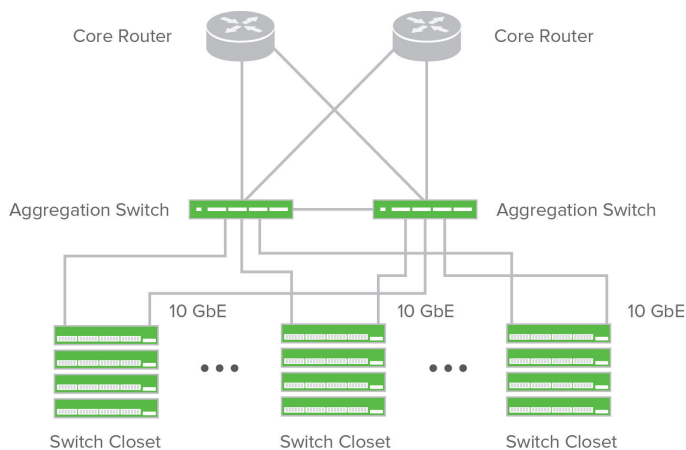

Full Enterprise Feature Set

Meraki switches include all of the traditional Ethernet features found in the enterprise:

- Quality-of-Service (QoS) to prioritize mission critical traffic such as voice and video
- IEEE 802.1X support for port based network access control
- MAC-based RADIUS auth and MAC whitelisting
- Voice VLAN support for simplified VoIP deployments
- Port Mirroring to monitor network traffic
- DHCP snooping to prevent users from adding unauthorized DHCP servers on the network
- IGMP Snooping to optimize network performance with multicast traffic
- Link Aggregation Control Protocol (LACP) for high-capacity trunking, stacking, and increased availability
- Broadcast storm protection, spanning tree, BPDU guard, root guard, and other safeguards to guard against misconfigurations and reduce convergence time
- Per port VLAN configuration
- Multiple administrative roles with sophisticated security policy management

Lifetime Warranty with Next-day Advanced Replacement

Cisco Meraki MS switches include a limited lifetime hardware warranty that provides next-day advance hardware switch replacement as long as the original purchaser owns the product. Meraki's simplified software and support licensing model also combines all software upgrades, centralized systems management and phone support under a single, easy-to-understand model.

For complete details, please visit www.meraki.cisco.com/support

Models

MODEL	DESCRIPTION
MS410-16-HW	Cloud-managed 16 port 1 GbE aggregation switch
MS410-32-HW	Cloud-managed 32 port 1 GbE aggregation switch
MS420-24-HW	Cloud-managed 24 port 10 GbE aggregation switch
MS420-48-HW	Cloud-managed 48 port 10 GbE aggregation switch

Accessories / Optics

The Meraki MS support pluggable optics for high-speed connectivity. Meraki offers several standards-based Gigabit and 10 Gigabit pluggable modules.

Supported Meraki accessory modules for MS Switches (no lock-out of third-party optics):

PART	DESCRIPTION	STANDARD	RANGE	COMPATIBILITY
MA-SFP-1GB-TX	Meraki 1GbE Module for Category 5 Copper Wire, RJ-45	1000BASE-T	100m	MS200/300/400 Series
MA-SFP-1GB-SX	Meraki 1 GbE SFP SX Multi-Mode Fiber Module	1000BASE-SX	550m	MS200/300/400 Series
MA-SFP-1GB-LX10	Meraki 1GbE SFP LX10 Single-Mode Fiber Module	1000BASE-LX10	10km	MS200/300/400 Series
MA-SFP-10GB-SR	Meraki 10 GbE SPF+ SR Multi-Mode Fiber Module	10GBASE-SR	400m	MS300/400 Series
MA-SFP-10GB-LRM	Meraki 10 GbE SPF+ LRM Multi-Mode Fiber Module	10GBASE-LRM	220m	MS300/400 Series
MA-SFP-10GB-LR	Meraki 10 GbE SPF+ LR Multi-Mode Fiber Module	10GBASE-LR	10km	MS300/400 Series
MA-CBL-TA-1M	Meraki 10 GbE Twinax Cable with SFP+ Connectors	10GSFP+Cu	1m	MS200/300/400 Series
MA-CBL-TA-3M	Meraki 10 GbE Twinax Cable with SFP+ Connectors	10GSFP+Cu	3m	MS200/300/400 Series
MA-CBL-40G-50CM	Meraki 40GbE Stacking Cable, 0.5 Meter	40GBASE-QSFP	0.5m	MS350/410
MA-CBL-40G-1M	Meraki 40GbE Stacking Cable, 1 Meter	40GBASE-QSFP	1m	MS350/410
MA-CBL-40G-3M	Meraki 40GbE Stacking Cable, 3 Meter	40GBASE-QSFP	3m	MS350/410
MA-FAN-16K	Field replaceable 16K rpm front-to-back fan	-	-	MS350/410
MA-FAN-18K	Field replaceable 18K rpm front-to-back fan	-	-	MS420
MA-PWR-250WAC	Field replaceable 250W power supply	-	-	MS300/400 Series

Note: Meraki SFPs use LC connectors. Meraki does not guarantee third-party optic and support.

Specifications

Management

Managed via the Web via the Meraki cloud management platform
Integrated with Meraki wireless, security appliance, and device management No-touch remote deployment (no staging needed)
Detailed historical per-port and per-client usage statistics
DHCP, client, and hostname fingerprinting
SNMP and traps
Seamless firmware upgrades

Remote Diagnostics

Email and SMS (text) alerts ¹
Live remote packet capture
Aggregated event and configuration change logs with instant search

Scalable Stacking

Virtually Stacking supports thousands of switch ports in a single logical stack for unified management, monitoring, and configuration
Physical stacking of up to 8 switches with 160Gbps stack bandwidth (MS410)

Ethernet Switching Capabilities

802.1p Quality of Service prioritization
802.1Q VLAN tagging for up to 4095 VLANs
802.1D Spanning Tree Protocol (STP) and 802.1w Rapid Spanning Tree Broadcast storm control
802.1ab Link Layer Discovery Protocol (LLDP) and Cisco Discovery Protocol (CDP)
802.3ad Link aggregation with up to 8 ports per aggregate
IGMP snooping for multicast filtering
Cisco Discovery Protocol (CDP)
128K MAC Forwarding Table Capacity (96K on MS410)

Layer 3 capabilities ²

Static routing
DHCP helper
DHCP server
Open shortest path first (OSPF v2)
Warm spare for L3 gateway redundancy ³
Automatic DHCP failover in warm spare mode

Performance

Non-blocking fabric
960 Gbps switching capacity on the MS420-48
480 Gbps switching capacity on the MS420-24
72 Gbps switching capacity on MS410 (16 & 32 port)
1.2 microsecond latency

Interfaces on MS410

16 or 32 x 1GbE SFP + 2 or 4 x 10GbE SFP+ uplink ports, 2 x stacking ports
1x 10/100/1000 RJ45 Management port

Interfaces on MS420

24 or 48 x 10GbE SFP+/SFP
1x 10/100/1000 RJ45 Management port

Power

Power input: 100 - 240 VAC, 47-63 Hz
Power consumption at idle: 45W (MS420), 50W (MS410)
Power consumption full load: 175W (MS420), 85W (MS410)

Environment

Operating temp: 0C to 40C

Mounting

Rack-mountable with included rack mount hardware
Front-to-back airflow

Physical dimensions

Weight: 18.1lb. (8.18kg) for MS420-48, 12.6lb. (5.7kg) for MS410-32
Size (420): 17.3" (w) x 18.6" (d) x 1.8" (h) (44x 47.3x4.5 cm)
Size (410): 19" (w) x 20.3" (d) x 1.8" (h) (48.5x 51.6x 4.5cm)

Regulatory

CSA (US)
IC (Canada)
CE (Europe)
C-Tick (Australia/New Zealand)
RoHS

¹ Requires carrier-supported email to SMS gateway

² Layer 3 with stacking available Q2 CY2016

³ OSPF and Warm Spare do not operate concurrently

Model	MTBF	Model	MTBF
MS420-24	225,540 hrs	MS410-16	875,186 hrs
MS420-48	203,102 hrs	MS410-32	437,593 hrs